

Direct current dimmable (TRAILING EDGE-LEADING EDGE) electronic drivers with DIP-SWITCH
Alimentatori elettronici regolabili (IGBT-TRIAC) in corrente continua con DIP-SWITCH

Made in Europe



3.1.3

Dimmable multipower DIP-SWITCH drivers - Compact case - PHASE CUT
Alimentatori multipotenza regolabili con DIP-SWITCH - Formato compatto - TAGLIO DI FASE



Rated Voltage
Tensione Nominale
220 ÷ 240 V

Frequency
Frequenza
50...60 Hz

AC Operation range
Tensione di utilizzo AC
198 ÷ 264 V

DC Operation range
Tensione di utilizzo DC
176 ÷ 264 V
(NO IGBT/TRIAC)
(NO PUSH mode function)

Power
Potenza
0 ÷ 32 W

Output current ripple
≤ 3%⁽¹⁾

Reference Norms
Norme di riferimento
EN 50172 (VDE 0108)
EN 55015

EN 61000-3-2
EN 61000-3-3
EN 61347-1
EN 61347-2-13
EN 61547
EN 62384
VDE 0710-T14

Lamps
Lampade:
Power LED
LED modules

Max. pcs for CB B16A
(see page info17)
50 pcs

In rush current
5A 50µsec

Article Articolo	Code Codice	P out W	V out DC	I out DC	V out max.	ta °C	tc °C	λ max. Power Factor	η max. Efficiency ⁽¹⁾		
DC JOLLY MD	122260	Constant current output - Uscita in corrente costante					-25...+50	75	0,97	>85	
		17	2...47	350 mA cost.	55						
		24	2...47	500 mA cost.							
		25	2...47	550 mA cost.							
		32	2...46	700 mA cost.							
		32	2...43	750 mA cost.							
		Constant voltage output - Uscita in tensione costante									
		10	12 cost.	900 mA max.	-	-25...+50					
		20	24 cost.	900 mA max.	-						
		22	28 cost.	900 mA max.	-						

⁽¹⁾ Referred to $V_m = 230$ V, 100% load - Riferito a $V_m = 230$ V, carico 100%

Accessories not supplied - Accessori non a corredo		
Article - Articolo	L (length)	Code - Codice
Synchronization cable Cavetto di sincronizzazione	1,5 m / 4 ft	485720512
	4 m / 13 ft	485720513
	50 cm / 19,68"	485720515
	20 cm / 7,87"	485720516
REG 1-10 V (pag. 341)		123999L
BMU DMX INTERFACE (pag. 346)		122066
ZLL INTERFACE (11.)		-
ETDU29 (pag. 339)		180426
ETD2E9 (pag. 338)		180427

Features

- Multipower driver supplied with dip-switch for the selection of the output current.
- IP20 independent driver, for indoor use.
- Class II protection against electric shock for direct or indirect contact.
- Active Power Factor Corrector.
- Current regulation ±5 % including temperature variations.
- Input and output terminal blocks on the opposite side (wire cross-section up to 2,5 mm² / AWG13).
- Clamping screws on primary and secondary circuits for cables with diameter: min. 3 mm - max. 8 mm.
- Double terminal blocks to loop other driver.
- Protections:
 - against overheating and short circuits;
 - against mains voltage spikes;
 - against overloads.
- Thermal protection = C.5.a.

Caratteristiche

- Alimentatore multipotenza fornito di dip-switch per la selezione della corrente in uscita.
- Alimentatore indipendente IP20, per uso interno.
- Protetto in classe II contro le scosse elettriche per contatti diretti e indiretti.
- PFC attivo.
- Corrente regolata ±5 % incluse variazioni di temperatura.
- Morsetti di entrata e uscita contrapposti (sezione cavo fino a 2,5 mm² / AWG13).
- Serracavo su primario e secondario per cavi di diametro: min. 3 mm - max. 8 mm.
- Doppia morsettiera lato rete per rimando ad altro alimentatore.
- Protezioni:
 - termica e cortocircuito;
 - contro le extra-tensioni di rete;
 - contro i sovraccarichi.
- Protezione termica = C.5.a.





Weight - Peso: gr. 185 / 6,52 oz.
 Pcs - Pezzi 40

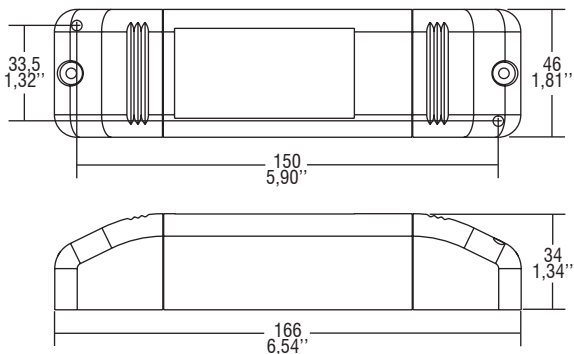

Wiring diagram - Schema di collegamento (Max. LED distance on page info8 - Massima distanza LED a pagina info8)

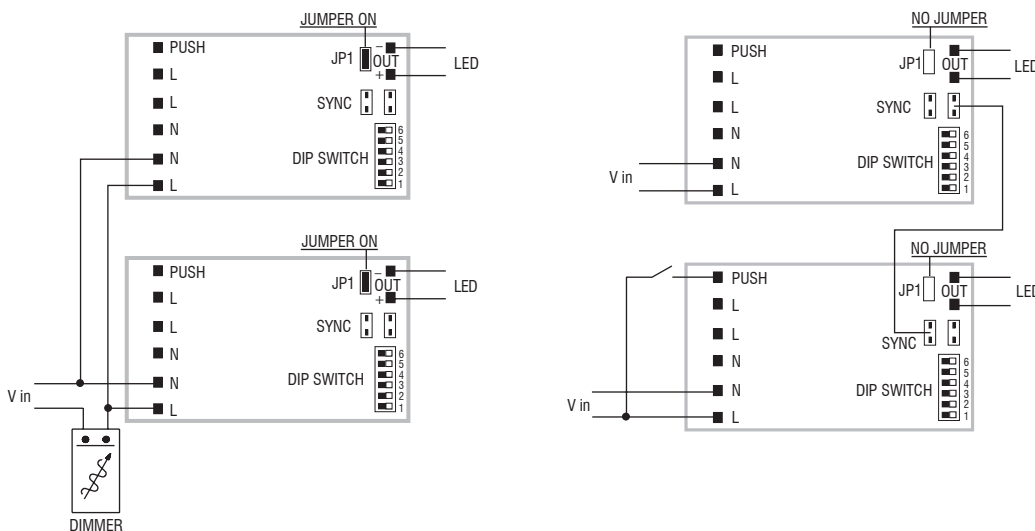

PHASE-OUT dimming - To avoid flickering, keep the slaves at 100% dimming level.
 Dimmerazione TAGLIO DI FASE - Per evitare flicker, i singoli slaves devono essere lasciati con dimming 100%.

PUSH diagram - Collegamento PUSH

Operation Mode

- Regulating driver with "phase cut-off" dimmer IGBT, TRIAC and PUSH.
 - Light regulation 0/0,5 - 100 % by means of PUSH function (mains voltage):
 - a short push to turn on and off;
 - a longer push to increase or decrease light intensity;
 - regulation automatically stops at minimum and maximum values;
 - for another on, regulation or off command, release the push button and give the desired command again;
 - dimming level memory at mains restore.
 - Maximum length of the cable, from push button to last transformer, must be max. 15 m / 49 ft. In case of applications where the cable is longer than 15 m / 49 ft, keep this separate from the 220 - 240 Volt mains cable.
 - **ATTENTION:** only use normally open push buttons with no incorporated warning light.
 - Max. 10 synchronised drivers of which only one can be controlled (1 Master + 9 Slaves).
 - Synchronization cable is separately supplied.
- For additional details for regulations see pages info12-14.

Modalità di funzionamento

- Alimentatore regolabile con dimmer a "taglio di fase" IGBT, TRIAC e PUSH.
 - Regolazione della luminosità 0/0,5 - 100 % mediante la funzione PUSH (tensione di rete):
 - una pressione breve per accendere e spegnere;
 - una pressione prolungata per aumentare o diminuire l'intensità luminosa;
 - la regolazione si ferma automaticamente ai valori minimi e massimi;
 - per un nuovo comando accensione, regolazione o spegnimento, rilasciare il pulsante e dare nuovamente il comando desiderato;
 - ripristino del livello di dimming al ritorno alimentazione.
 - La lunghezza massima del cavo, dal pulsante all'ultimo trasformatore, deve essere max. 15 m / 49 ft. In caso di applicazioni dove il cavo superi i 15 m / 49 ft, tenere lo stesso separato dal cavo di rete 220 - 240 V.
 - **ATTENZIONE:** usare solo pulsanti di tipo normalmente aperto privi di spia luminosa incorporata.
 - Max. 10 alimentatori sincronizzati, di cui uno solo comandato da uno o più punti (1 Master + 9 Slaves).
 - Cavetto per la sincronizzazione fornito separatamente.
- Per ulteriori dettagli sulle regolazioni vedi pagine info12-14.

3.1.3

Dimmable multipower DIP-SWITCH drivers - Compact case - PHASE CUT
 Alimentatori multipotenza regolabili con DIP-SWITCH - Formato compatto - TAGLIO DI FASE